

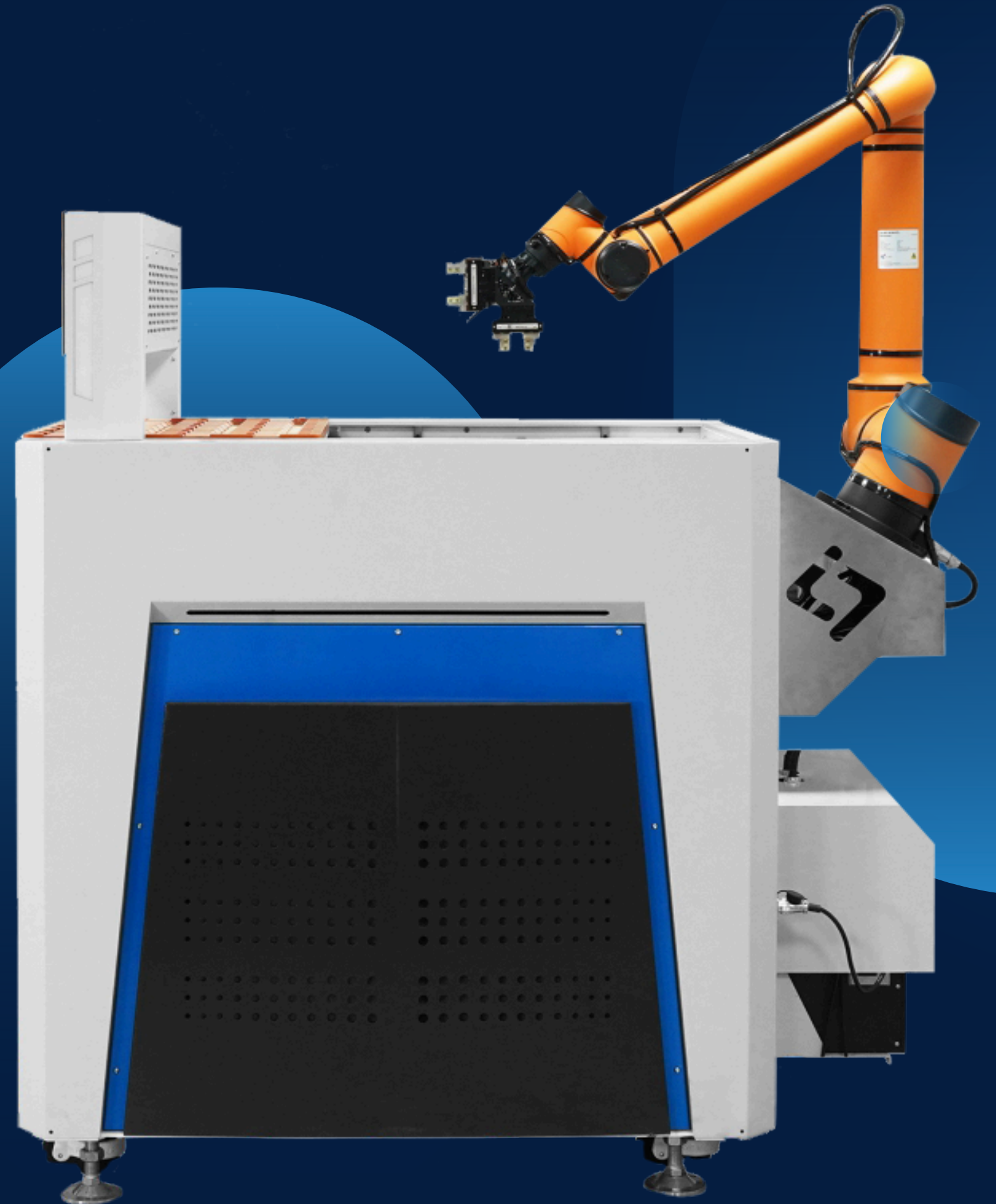

RI CNC TENDING COLLABORATIVE STATION



ABOUT US



Our Mission

With a presence on 2 continents, consisting of manufacturing capabilities in Asia and Engineering and R&D in both Asia and Europe, our mission is to support partners and end customers with advanced robotics solutions that help optimize operations and of costs, increasing productivity and eliminating risks of accidents and repetitive tasks for the human resource, the most valuable resource for any company.



Our Vision

Robot Industries International strives to be a reliable partner for small and medium-sized companies but also for brands with global reach. Whether it is industrial or collaborative robots, robots in cleaning or retail applications, intralogistics or disinfection applications, all these directions are already open doors for Robot Industries.

#RI SOLUTIONS



Industrial
Robots

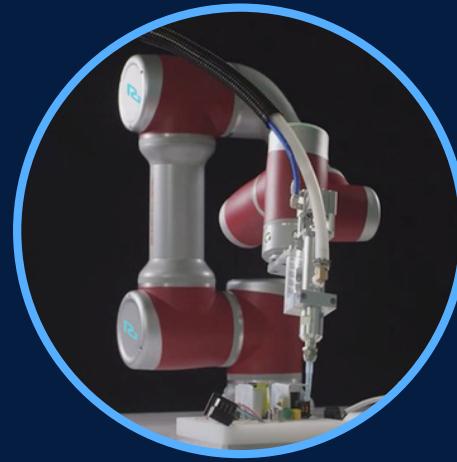

Collaborative
Robots



Intralogistic
Robots



Cleaning
Robots



Smart
Service
Robots



AI
Vision



RAPID
SETUP



RAPID
PROGRAMMING



LARGE
STORE
CAPACITY



MOBILE
PLATFORM

TECHNICAL PARAMETERS

| Model | RI-T10 | RI-T12 | RI-T20 |
|-------------|--|---------|---------|
| Load | 10 kg | 12 kg | 20 kg |
| Arm reach | 1350 mm | 1250 mm | 1650 mm |
| DOF | 6-AXIS | | |
| Tray size | 600*480 mm | | |
| Layer | 10 layer Options 9 layer and 8 layer | | |
| Object | 60mm (10layer) 70mm (9layer) 80mm (7layer) | | |
| Power | Single phase 220V (110V options) | | |
| DI/O | 16 Input/16Output | | |
| Protocol | Ethernet, Modbus-RTU/TCP, Profinet(Options) | | |
| Weight | 420 kg | | |
| Application | For CNC lathe, milling EDM, Test machine load and unload | | |
| Language | English | | |
| Other | Siemens PLC and HMI | | |

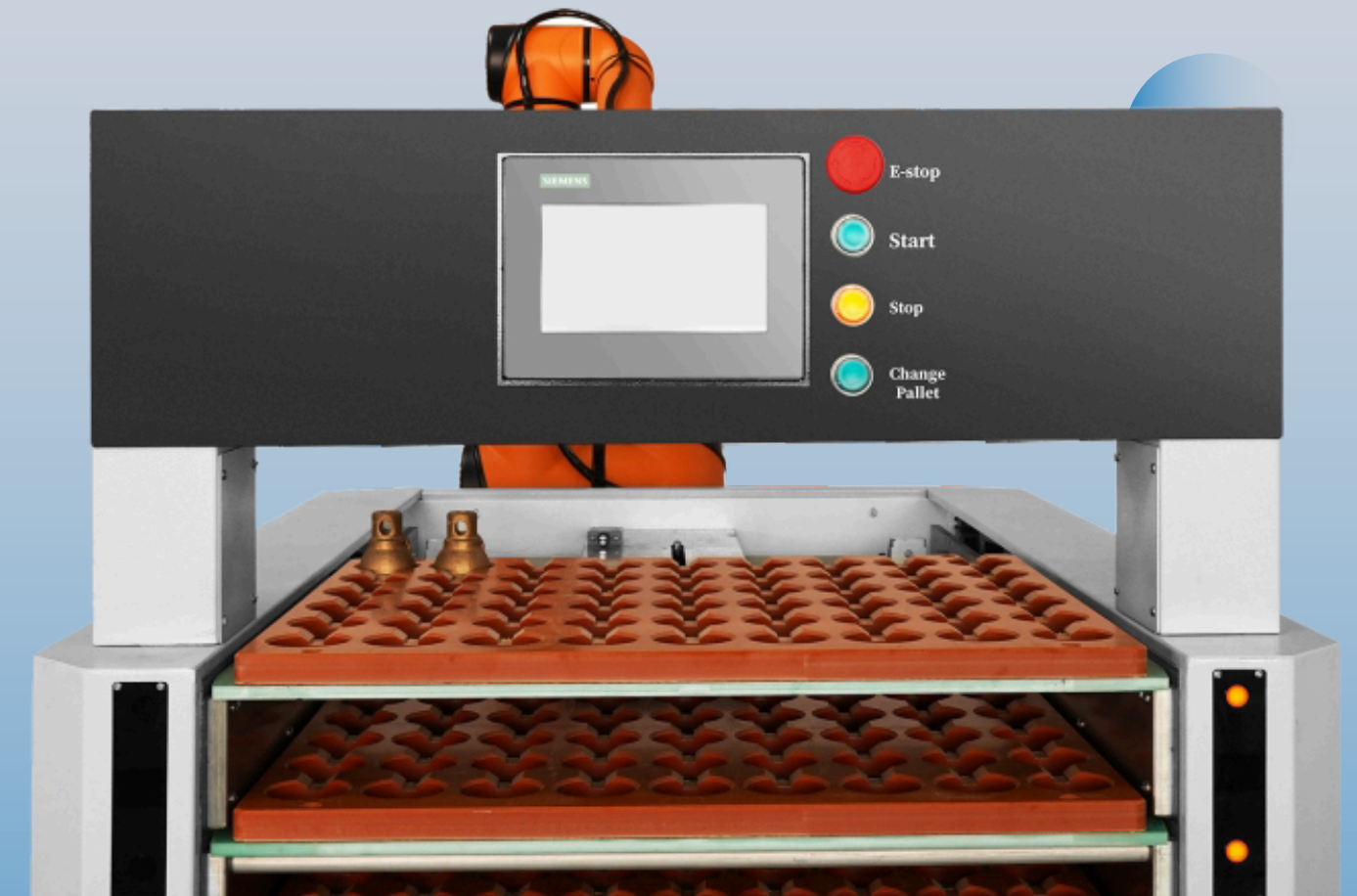

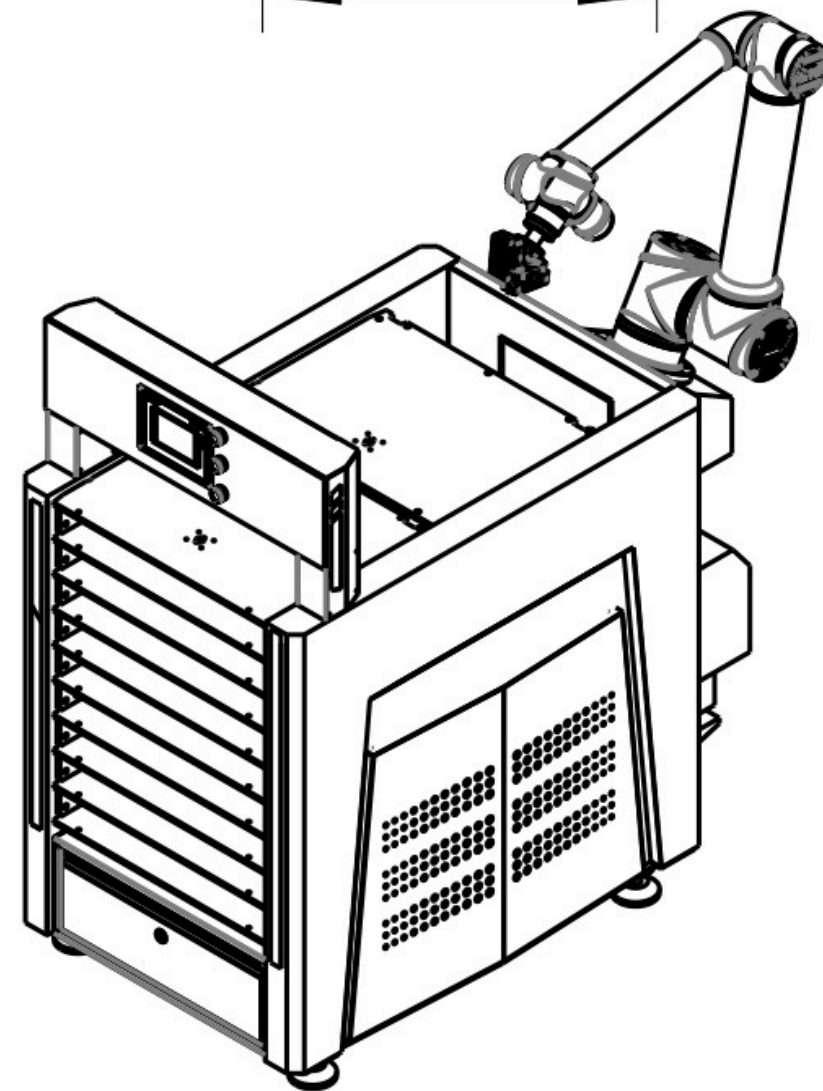
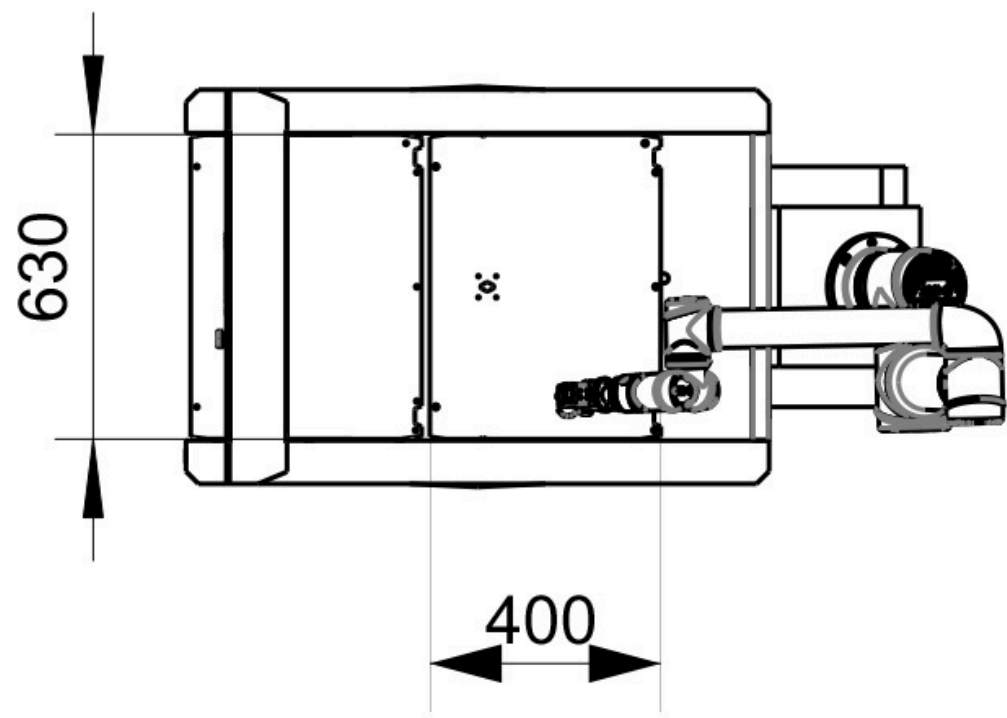
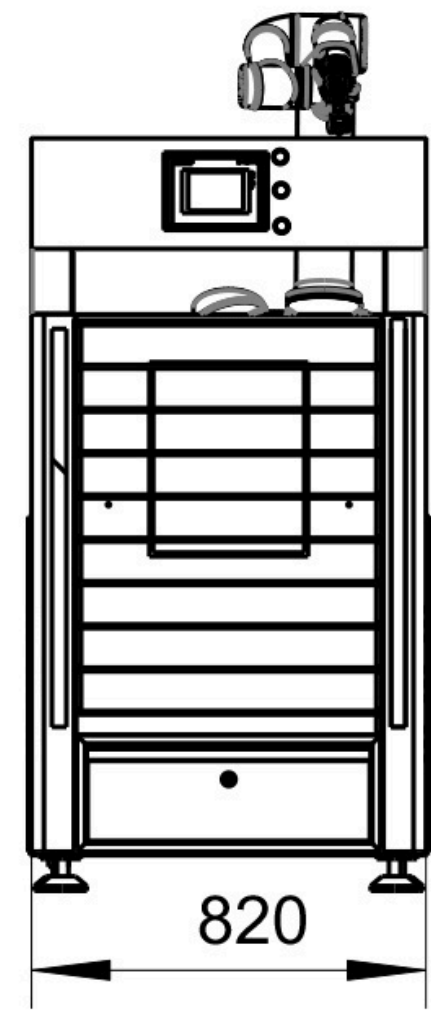
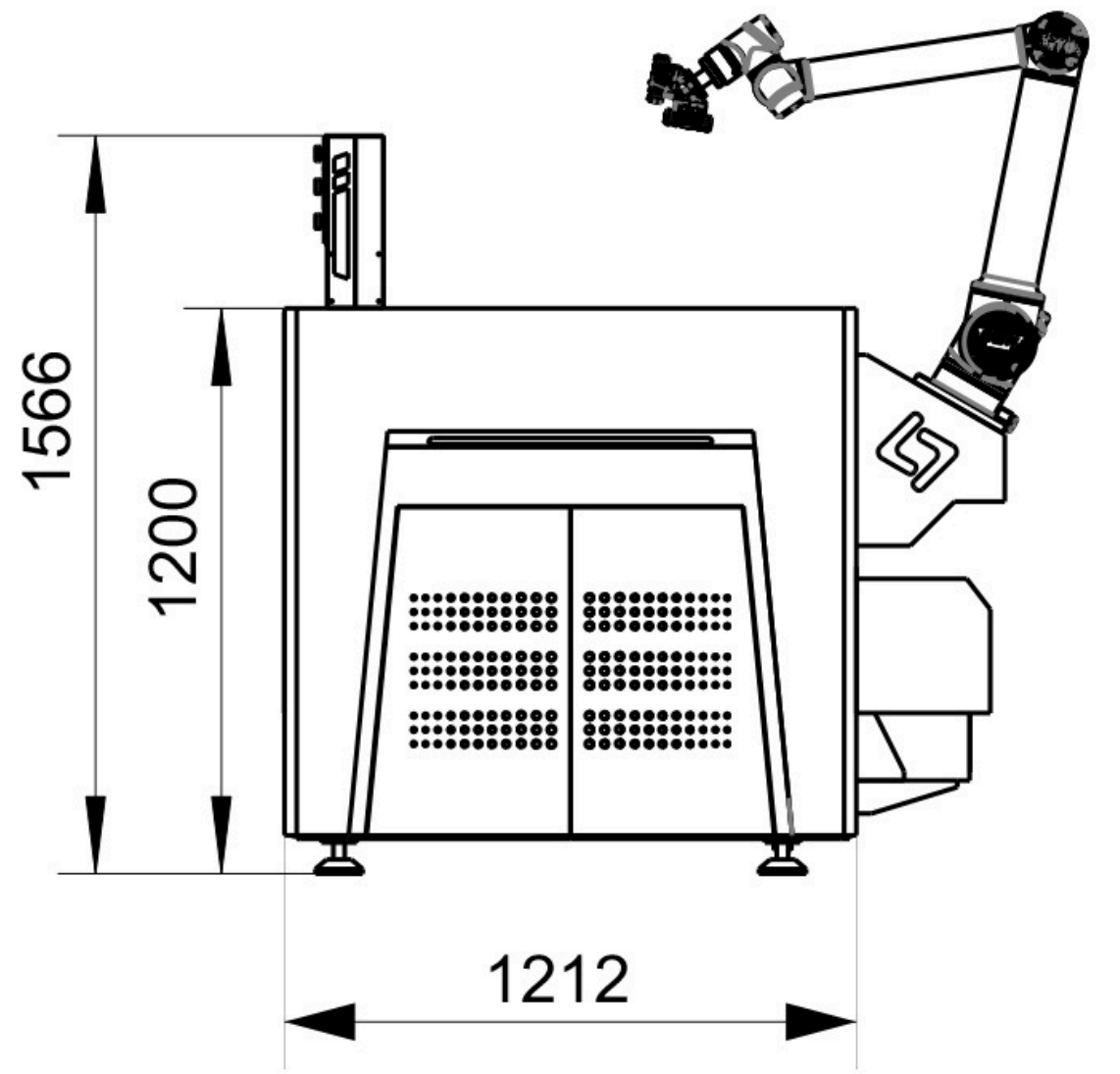

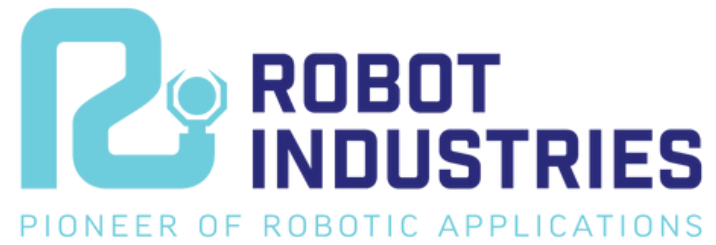

 sales@robotindustries.com

 www.robotindustries.com

 **Headquarter**

- Südwestkorso 14 12161, **Berlin, Germany**
- Building 2, Phase II, Jingang Science Park, No. 1, Kechuang Road, Yaohua Street, Qixia District, **Nanjing, China**

