

## RI1 - 4 IN 1 CLEANING ROBOT



# Content

**01**

**Product Overview**

**02**

**Product Advantages**

**03**

**Product Values**

**04**

**About RI**



Emergency Button

Touch Screen

RGBD

Ultrasonic Radar

Main Lidar

RGBD

Rolling Brushes

Side Brush



Handle

Top-view Camera

Turn Indicator

Water Refilling  
Solid-state Lidar

Wireless Charging

Water Drainage

Squeegee



<b>Machine Dimension</b>	663*568*682mm
<b>Machine weight</b>	69kg
<b>Sweeping Width</b>	500mm
<b>Scrubbing Width</b>	400mm
<b>Water Tank Capacity</b>	Clean Water Tank 15L Waste Water Tank 15L
<b>Charging Time</b>	< 3h
<b>Run-time</b>	Max 8h
<b>Cleaning Efficiency</b>	700-1000m <sup>2</sup> /h
<b>Cleaning Operating Noise</b>	< 70dB
<b>Cruise Speed</b>	Max 1.2m/s
<b>Local Interaction</b>	10.1-inch touch screen
<b>Positioning Method</b>	Visual + Laser Positioning

# Content

01

Product Overview

02

Product Advantages

03

Product Values

04

About RI



## Four-in-one Versatile Cleaning

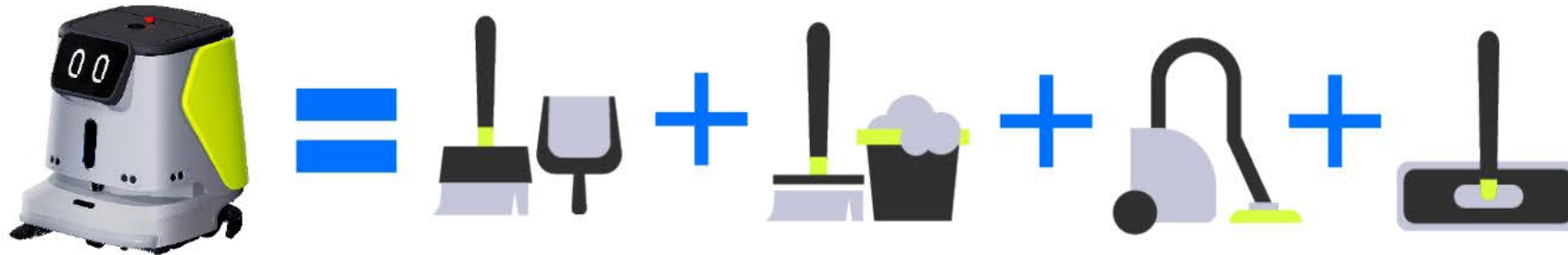

- **Sweeping, Scrubbing, Vacuuming and Dust Mopping** multi-function in one. All cleaning needs can be easily met by one machine.
- **Two main cleaning modes:**
  1. Sweeping + Vacuuming + Mopping
  2. Scrubbing
- **Modular Component Design:** Removing the accessory is no longer a tedious task, but a fast and efficient one. **Accessories (such as side brush, roller brush, squeegee, and mopping sweeper)** can be loaded and unloaded within **1 minute**.

## Suit Various Floor Types

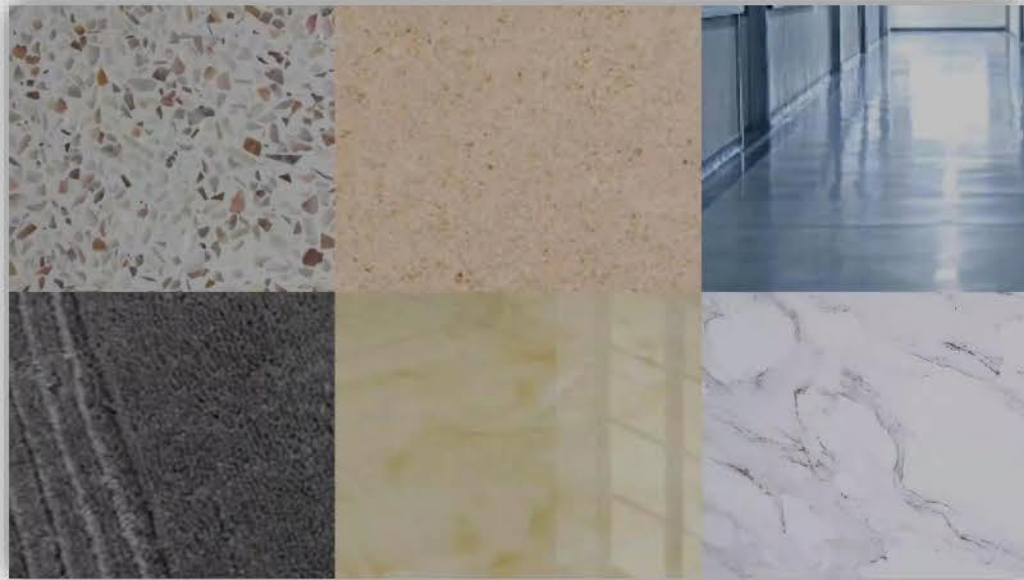

- Suitable for indoor floors with **different materials and hardness**:
- **Hard floor**: Nature Stone, Terrazzo, marble, floor tile, epoxy resin, sandstone, artificial stone flooring, etc.
- **Soft floor**: Low-pile carpet



## Fit Corners Perfectly



- **Ultimate edge cleaning (< 6cm edge to edge)** in certain scenes with side brushes. It performs edge sweeping well with no trash left behind.

## Automatic Recharging

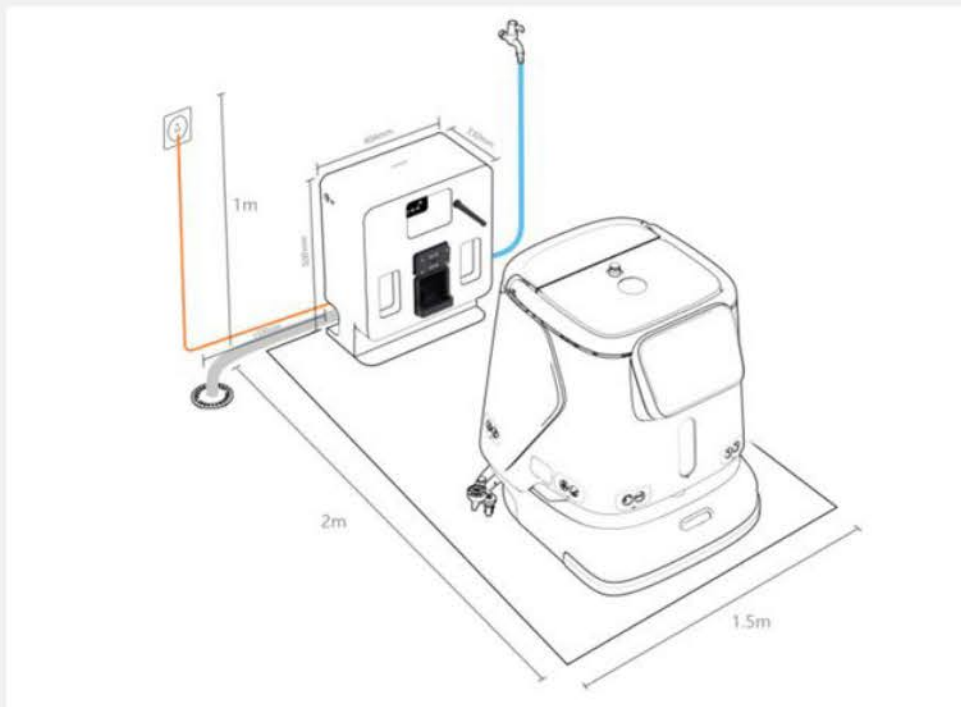

- **The robot will automatically return to the workstation\*** when the power is low.

\*The workstation needs to be purchased additionally

## Automatic Water Addition & Drainage



- **Large Capacity: 15L clean water tank and 15L waste water tank** with an exclusive workstation
- **Automatically fill and drain the water** at the workstation\*
- No manual intervention, worry-free and labor-saving

## Digital Cleaning

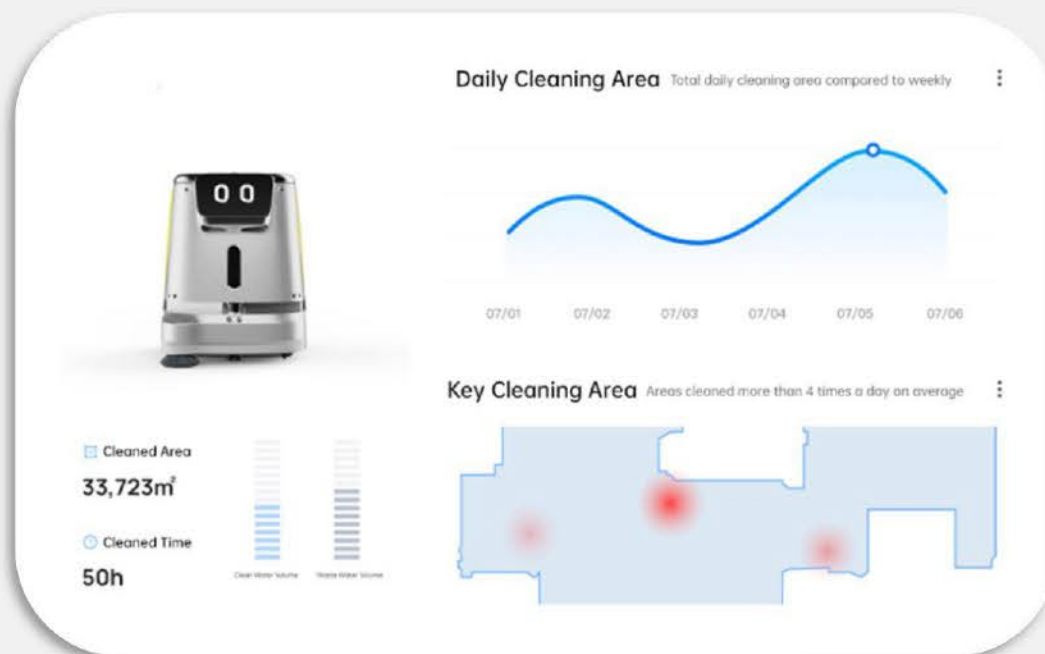
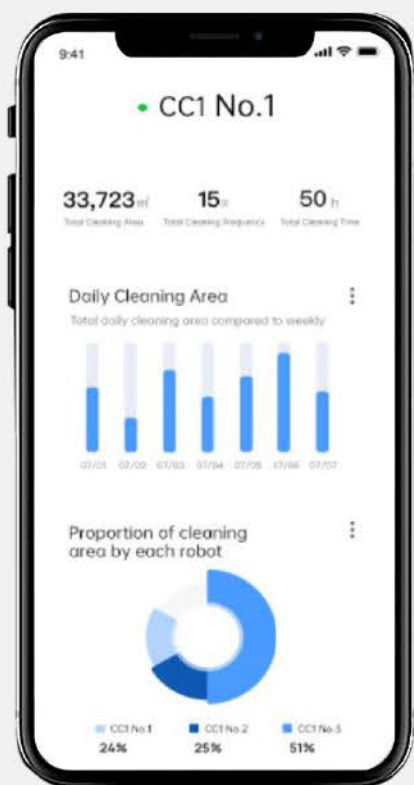

- **Remote operation** via APP, work status can be checked at any time.
- Get **real-time notifications** for cleaning performance, such as cleaning time and cleaning area.
- **Digitization and visualization** of cleaning effects: collect and summarize the **working status** of each unit, and automatically generate cleaning reports.

## Automatic Localization & Navigation

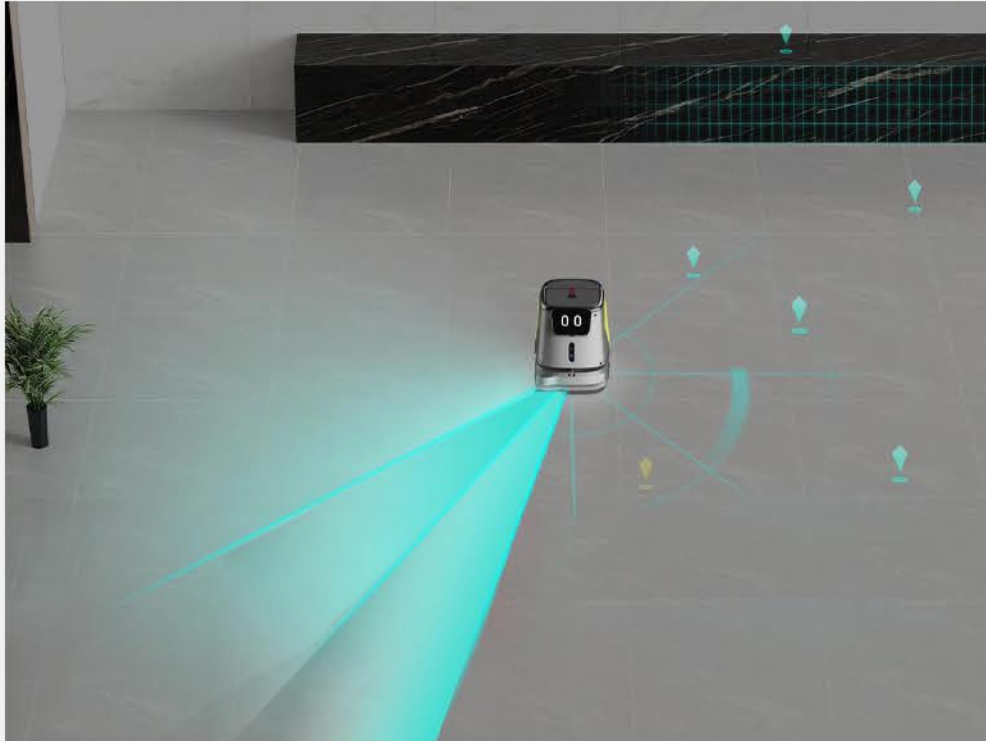

- Based on PUDU SLAM positioning system, CC1 supports both **Visual SLAM and Laser SLAM positioning and navigation** solutions to perform tasks more efficiently in complex scenarios.
- Equipped with **Multi-fusion sensors**, it can stop at any angle and move away as soon as it encounters obstacles.



## Breakpoint Resume Cleaning

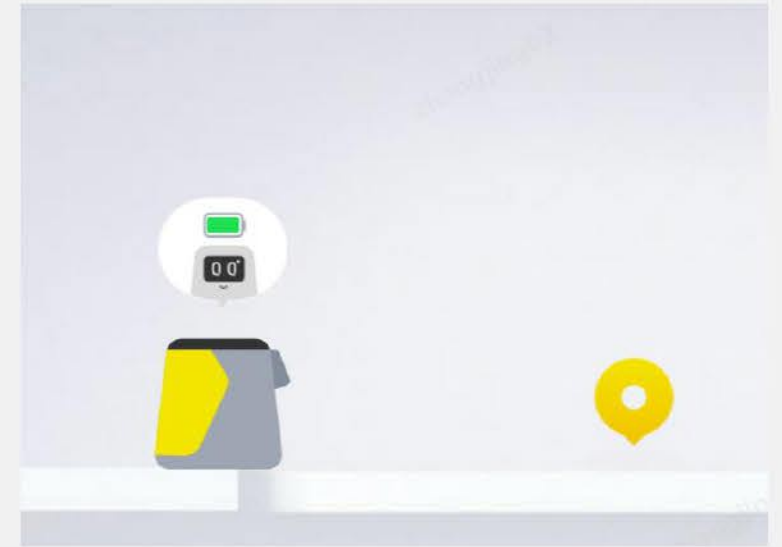
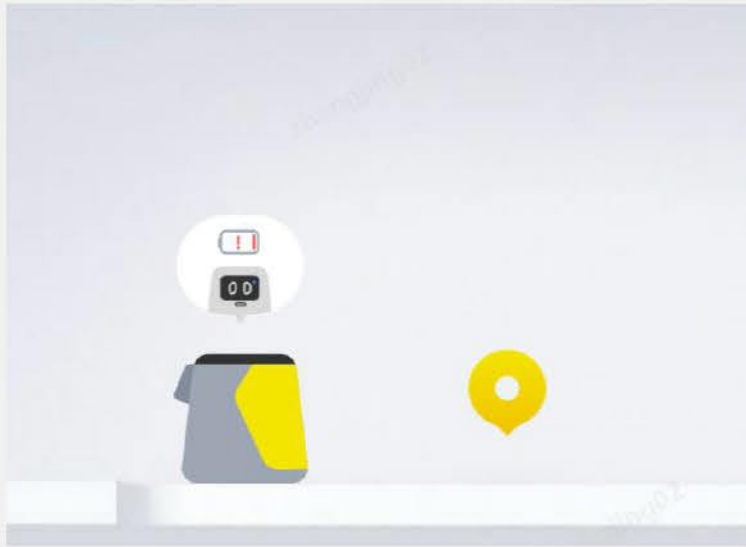

- When the power is low and the cleaning task is not completed, the robot can **remember the cleaning progress** and **resume the previous unfinished task** after being fully recharged.

## Multi-machine Intelligent Scheduling

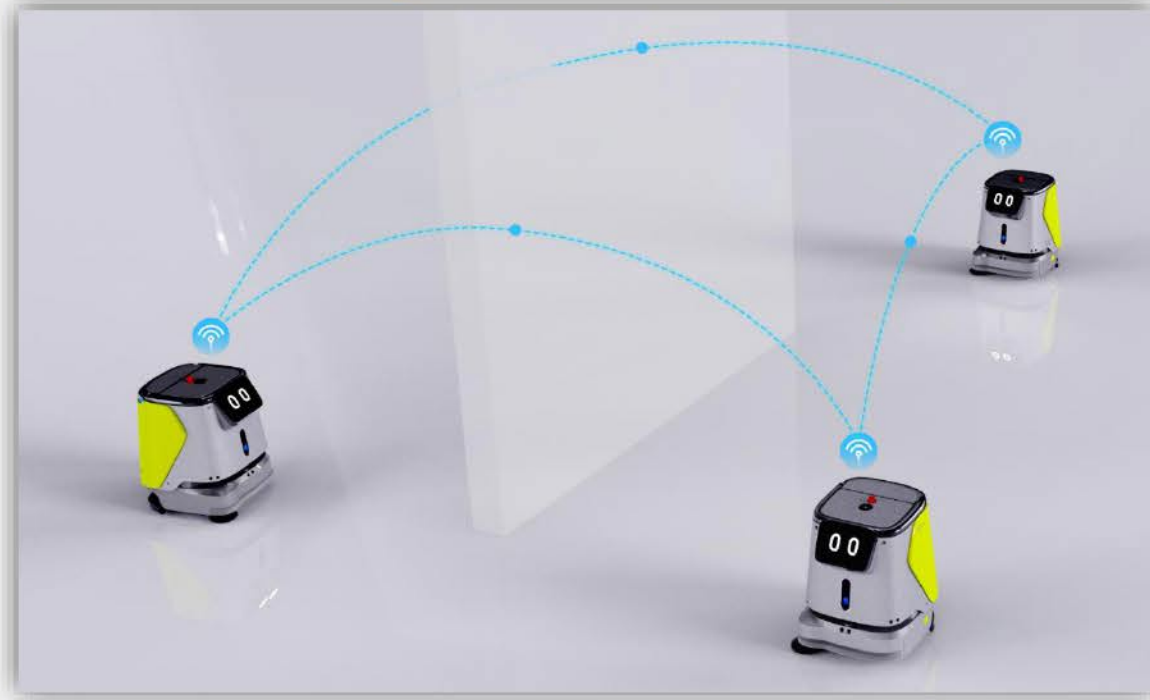

- Based on PUDU Scheduler technology, it supports **multi-machine intelligent scheduling** and realizes multi-machine collaborative operation, automatic replacement, multi-machine to multi-workstation and other functions, and realizes the systematic operation of robots in office buildings/residential buildings.

# Content

**01**

**Product Overview**

**02**

**Product Advantages**

**03**

**Product Values**

**04**

**About RI**

## RI1 - 4 IN 1 CLEANING ROBOTS

### Intelligent Commercial Cleaning Robot

- Enhances cleaning efficiency and public image
- Improve cost effectiveness and cleaning quality
- Reallocates custodial efforts to higher-value tasks
- Provides detailed reports for a measurable clean





- **Simplify your cleaning processes** and improve your workflow: pre-set program enables CC1 to start operating automatically and immediately
- Stable cleaning efficiency and **higher quality of cleaning**



- **Reduce risks of workforce challenges**, such as employee absenteeism and turnover
- **Redeploy labor**: Employees can focus on more complex responsibilities, ensuring more productivity.



- **Lower** recruitment, training and management **costs**: simple operation and user-friendly interface, set up and use in hours with minimal training



- With **measurable records and reports**, custodial inspections can be easily dealt with, and work status can be optimized.





**Office Building**



**Education**



**Retail**



**Food & Beverage**



**Public Transportation**



**Health Care**



**Manufacturing**

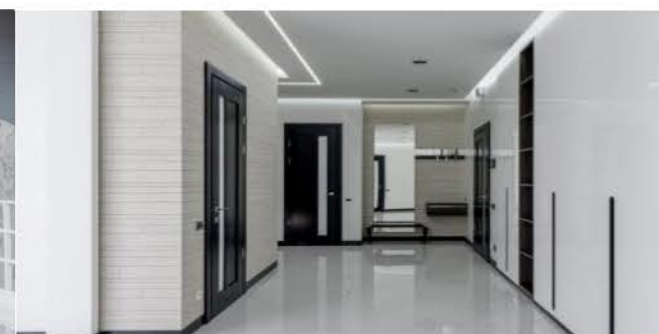

**Hospitality**