



ROBOT INDUSTRIES
CleanX R3 5-IN-1 AI CLEANING ROBOT

USER MANUAL



CONTENTS

1. Safety Specification	1
2. Delivery List	2
3. Status Reminder Icons	3
4. Introduction to Robot Control Panel	4
5. Introduction to Control Panel of Charging Dock	5
6. Preparatory Work	6
6.1 Inspection of Internal Devices.....	6
6.2 Charging Dock Deployment.....	9
6.3 First Charging of Robot.....	11
7. Structural parts installation	17
7.1 Side Brush Installation.....	17
7.2 Rolling Mop Installation.....	19
7.3 Rolling Brush Installation.....	21
7.4 Wipe Plate Installation.....	23
7.5 Side Plate Installation.....	26
7.6 Installation of Rear Cover Plate.....	28
8. Structural Parts Disassembly	29
8.1 Dismantling of Robot Side Plate.....	29
8.2 Dismantling of Rear Cover Plate.....	30
9. Basic Parameters	31
10. Common Problems	32
11. Service Life of Relevant Components	33

Restrictions of Use

- Please use the Product in accordance with this Manual; otherwise, its warranty shall be terminated. Any losses and injuries due to improper use shall be undertaken by the users.
- The Product applies to cleaning of indoor hard floor, such as ceramic tile, marble and wooden floor. Do not use it for outdoor environment (such as outdoor space, balcony, etc.), such as cleaning of shag carpet, deep-color carpet, etc.
- The Product supports cliff identification function. However, the user should set fences at the staircase, steps or other suspended places, and do not place the low objects such as floor mat, shoes, etc. at the positions above; otherwise, the Product may fall down due to the failure of cliff sensor.
- It is not advised to use the Product in places with temperature above 40 Celsius, below 0 Celsius, or the floor that has oil stain, sugared beverage and consistent materials. Make sure to place the base station on indoor and horizontal floor, and keep away from open flame, heat source, water, narrow or suspended area.
- Do not insert your fingers into the Product's gap, or keep the hair and limbs, etc. of human and animals away from the rotating position of brush head, to avoid injury.
- Keep the Product inaccessible to children under age 7, the pets or other personnel who have physical, mental or perceptual disorder, in order to avoid an injury.
- While the Product is running, avoid hard or sharp objects (such as decoration waste, shattered glass, iron nails, etc.), druggable sundries (such as rope, electric wire, cable, plastic bag, etc.) on the floor where the Product works. The valuables and fragile products should stay away from the Product's working area and be provided with necessary protections.
- Do not clean the burning substance (such as unextinguished cigarette end, match, ash, etc.).
- Do not use the Product for cleaning or sucking the inflammables and explosives (such as lighter, gasoline, printer, or the color matching agent and toner, etc.).
- Do not sit or stand on the Product and the multi-function charging dock (charging dock).
- Do not put any foreign matters on the charging dock.
- Please carry out cleaning or maintenance of the Product or its base station under shutdown or power-off status. Do not use the wet cloth that has water dropping or seepage for wiping the Product. The user can dismantle the mop for cleaning, then install it back after cleaning (when mop has water dropping, handle it manually in time or dry it).
- Do not pour water, waste or dust into the dust tank, for it may possibly bring water into the fan and cause damages.
- Do not add other liquids other than clean water and tap water in the clean water tank; do not pour sewage, waste or sands into the sewage tank; otherwise, the Product and charging dock can have severe damages.
- Before handling the Product, make sure to power it off, and it is advised to use the original package box for packaging. Do not uplift the charging dock bottom plate directly for handling, nor use the protective cover of the Product's laser ranging sensor, upper cover, collision buffer, charging dock cover plate or water bucket handle for handling the Product, to avoid part falling, laser dislocation or other damages.

- Put the charging dock against the wall, do not stack any other objects nor put obstacles within 1.5m at front or within 0.5m at lateral sides.

Battery and Charging

- It is forbidden to use the Product along with any type of power converter; otherwise, its warranty shall be terminated. Any losses and injuries due to improper use shall be undertaken by the users.
- Make sure to press the battery button while charging the Product. It is forbidden to plug or unplug the battery under charging status.
- Type R3-D and G3-G robot supports Type CB-3 multi-function charging dock only.
- Make sure to confirm and use the qualified power supply that has reliable grounding; otherwise, electric shock may occur. When there's no power supply with reliable grounding, make sure it is rectified by a professional technician before using the Product.
- Do not dismantle, repair nor transfer the battery and charging dock without permission.
- Do not abandon the waste batteries randomly, but send them to the professional recycling institute for treatment.
- Do not use any third-party battery, charger, charging wire and charging dock, etc.
- Do not wipe or cleaning the charging spacer with wet towel, cloth or hands.
- Make sure the power voltage conforms to the voltage marked on charging dock before using the Product.
- Only the attached power cable of product can be used; otherwise, smoking, heating fire, etc. may occur.
- It is advised to take the corresponding protective measures when it has thunderstorm or unstable power supply and voltage where the Product is used.
- Do not use the damaged power cable. For any damage (including sheath damage and breaking, etc.), stop using the Product immediately, and contact the customer service staff in time.
- Please unplug the power socket before the charging dock is long idled.
- When the Product is idled for long period, please fully recharge it, then turn it off and put it in a cool and dry place, and recharge its battery once every three months to avoid over-discharge.

Laser Safety Information

- The Product's laser ranging sensor conforms to the Class 1 laser product standards of IEC 60825-1:2014 without generating any hazardous laser radiation.







Executive standard:

- EN 60204-1, EN ISO 12100, EN 60335-1, EN 60335-2-72, EN 61000-6-1, EN 61000-6-3, EN 61000-3-3, EN 61000-3-2, EN 60335-1, EN 300328, EN 301489-1, EN 301489-17, EN 301893, EN 300440, EN 62479, etc, EN 61558-1, EN 61558-2-16, EN 60204-1, EN 61000-62, EN 61000-6-4, EN IEC 61000-3-2, EN TEC 61000-3-3.

2. Delivery List

The Product has two types: R3-G (rolling brush version) and R3-D (single suction port version). Pay special attention during delivery, for their wiper strip and rolling brush installed at front of robot are different. The brush holder and rolling brush, which are mounted on the Product, are not included in the delivery list.

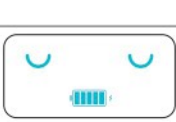
Component Type	Name	Qty.
General Accessories (which must be delivered)	CleanX R3 5-in-1 AI cleaning robot (attached with battery)	1 set
	Multi- functional charging dock RI3-C	1 set
	Side brush (2 pcs/set)	2 sets (4 pcs in total)
	Filter bag of sewage tank	5 pcs
	Front/rear wiper strip	1 pcs respectively (2 pcs in total)
	Rolling mop	1 set
	Rolling brush (White)	1 set
	Cleaning brush (covered with rubber bag)	1 set
	Clean water filter	2 pcs
Specific accessories for single suction port RI3-D (delivered by model)	RI3-D filter	1 pcs
	R3 -D disposable dust paper bag	10 pcs
	Clean water tank	1 set
	Single suction port sewage tank	1 set
Special accessories of rolling brush RI3-G (delivered by model)	Dust tank filter	1 pcs
	Sewage filter	1 pcs
	Dust bag	5 pcs
	Roller brush (black)	1 set
	Wiper strip of rolling brush	2 pcs
After-sales documents (placed in bag and attached at the top)	Operation instructions	1 pcs
	Certificate of conformity	1 pcs

Status	Robot Expression	Indicator Status	Introduction
Idle		Multi-color alternative flickering	When the Product is idle and has no operation.
Working		Blue indicator flickering	The Product is executing floor sweeping, cleaning, dust collection, etc.
Take a lift		Blue indicator flickering	The Product is taking a lift, including ascending/descending.
Recharging		Yellow indicator flickering	When battery level is below 10%, the Product will return to charging dock automatically for charging. When working voltage is below 24V, the Product will return to charging dock automatically for charging. When water level of clean water tank is too low, the Product will return to charging dock automatically for supplementation. When water level of sewage is too high, the Product will return to charging dock automatically for pumping sewage.
Charging in progress		Green indicator flickering (normally on after charging completes)	The Product is being charged by the multi-function charging dock.
Emergency stop		Multi-color alternating flickering	The Product stop running suddenly due to an emergency.
Fault		Red indicator flickering	The Product has a fault.

4. Introduction to Robot Control Panel

The Product's control panel is designed on its pull rod. Left button on pull rod: Set the cleaning mode, including vacuuming, mopping, dust-mopping; right button on pull rod: Switch robot status between continue/pause, homing, child lock.

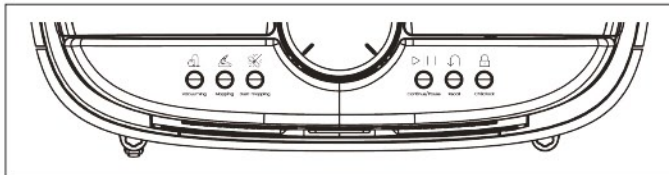

1 Vacuuming

Vacuumping button: Execute the task of single dust collection of entire site. It is effective when the Product has no task, and does not apply to task switching of the Product. (Attention: This button is disabled under child lock status).

2 Mopping

Mopping button: Execute the task of single floor cleaning of entire site. It is effective when the Product has no task, and does not apply to task switching of the Product. (Attention: This button is disabled under child lock status).

3 Dust-mopping

Dust-mopping button: Execute the task of single dust pushing of entire site. It is effective when the Product has no task, and does not apply to task switching of the Product. (Attention: This button is disabled under child lock status). The adhesive tape at the Product's end should be removed under dust pushing mode.

4 Continue/Pause

Continue/Pause button: Switch between "pause/continue" task status, and it will give out voice broadcast along with the task status; press and hold this button to cancel the task, and it will broadcast that current task is cancelled. (Attention: This button is disabled under child lock status).

5 Recall

Recall button: Cancel the task of robot in working status and return to the base station for charging and water exchange (Attention: This button is disabled under child lock status).

6 Child lock

Child lock button: Avoid affecting the cleaning task due to accidental pressing of this button. The child lock button is enabled by default, and other buttons will be disabled. Press this button for 3 times continuously to unlock child lock, and the indicator will turn off.

7 Pull rod

Pull rod: Switch between the manual and auto mode. The Product will enter auto mode when pull rod is put down, or enter manual mode when the pull rod is pulled up. The Product's cleaning mode will maintain unchanged under manual mode; the operator can push the Product to move through the pull rod.

5. Introduction to Control Panel of Charging Dock

The charging dock panel has 8 icons, in which, "clean water tank", "sewage tank", "wireless" and "power" icon are used for status display, while "discharge clean water", "discharge sewage", "charging" and "child lock" are operable buttons.

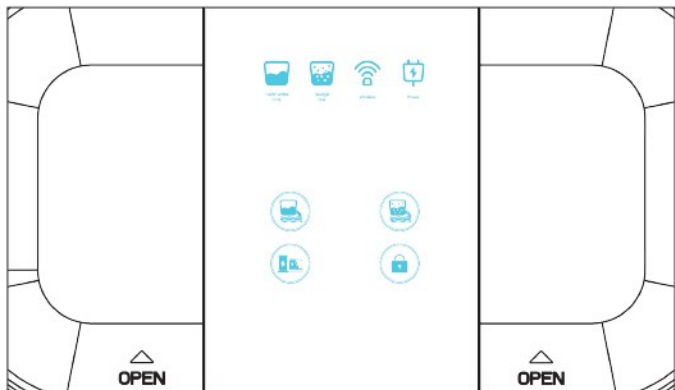

1 Status indicator of clean water tank:

Blue indicator normally on: Lower limit of water level is < water level of clean water tank
Red indicator flickering: Lower limit of water level is > water level of clean water tank.

2 Status indicator of clean water tank:

Blue indicator normally on: Lower limit of water level < water level of clean water tank
Red indicator flickering: Lower limit of water level > water level of clean water tank.

3 Wireless status indicator:

This indicator is off when field charging dock is unconnected to the Product; its blue indicator will be normally on when the field charging dock is matched with the Product successfully.

4 Power status indicator:

The power indicator on panel will be on when the charging dock is connected to power cable and the charging dock is powered on.

5 Indicator of discharging clean water button:

When power is connected and this button is pressed, its blue indicator will be normally on, and the water pipe at the clean water tank side behind the charging dock will start discharging of clean water.

6 Indicator of discharging sewage button:

When power is connected and this button is pressed, its blue indicator will be normally on, and the water pipe at the sewage tank side behind the charging dock will start discharging of sewage.

7 Charging button indicator:

This indicator will be on when the Product is being charged by charging dock; when the Product is completely out of power, push the Product to the charging dock, then hold the child lock button; when indicator of child lock button is off, press the charging button and its indicator will be on if there's good contact between the Product and charging dock, and the Product will start charging.

8 Indicator of child lock button:

This button can prevent affecting the cleaning tasks due to accidental pressing of button. The child lock button is enabled by default, and other buttons will be disabled. Press and hold this button to unlock child lock, and the indicator will turn off.

6. Preparatory work | Inspection of Internal Devices

6.1 Inspection of Internal Devices

Check if the Product's devices are installed completely according to the following steps:

- 1 Open the Product's cover, slightly lift the cover plate at the raised position near the pull rod.

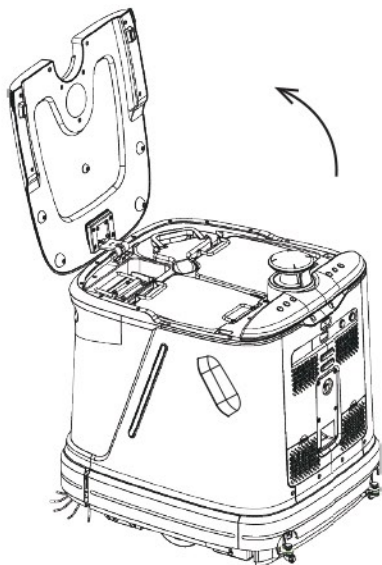

- 2 Uplift the dust bag, check if it is installed properly, and confirm that dust bag is firmly fixed with its handle.

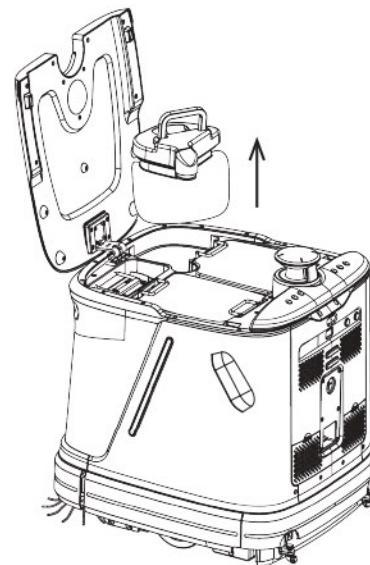

6. Preparatory work | Inspection of Internal Devices

- 3 Uplift the water tank, check if it is installed and the water tank cover is closed.

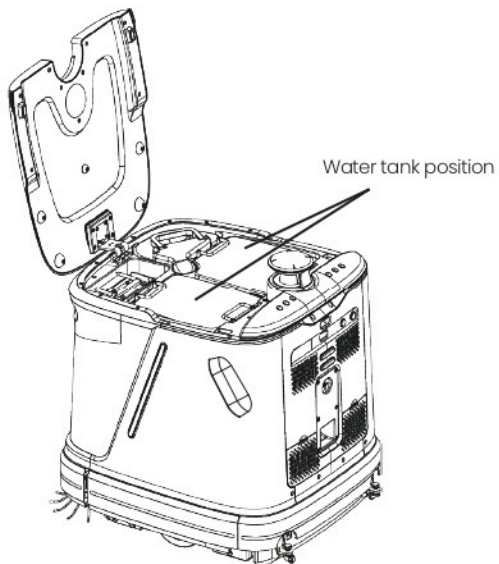

- 4 Check the battery appearance, and confirm that its surface has no structural damages such as concave.



- 5 Place the battery according to the direction indicated on battery guide slot, press the battery slight to ensure good contact with the Product.

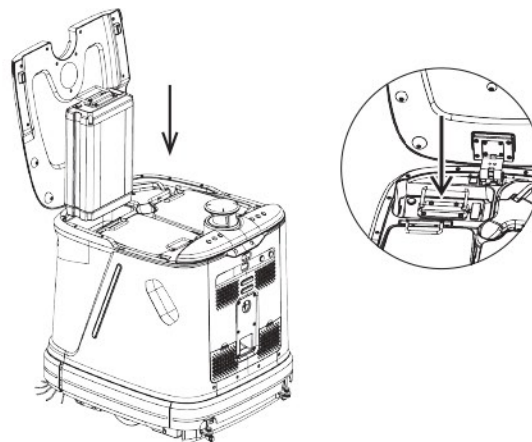

6. Preparatory work | Inspection of Internal Devices

- 6 When the button status is changed and the buzzer buzzes after the battery button is pressed, please press the battery button. (When battery button status does not change after pressing the button, the battery has an error and contact the manufacturer for replacement. When the buzzer buzzes after pressing the button, the battery is low and needs recharging).

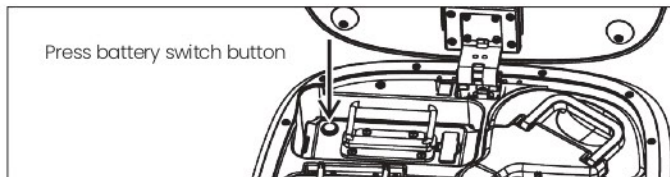

- 7 Close the Product's cover plate, and rotate the emergency stop button clockwise to release it.

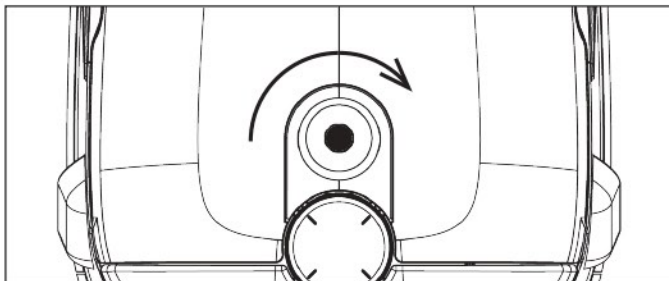

- 8 Press the switch button behind the Product and it will power on when the power indicator is on; it will broadcast "Welcome to use CleanX R3 5-in-1 AI cleaning robot" during startup.

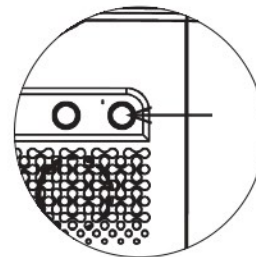
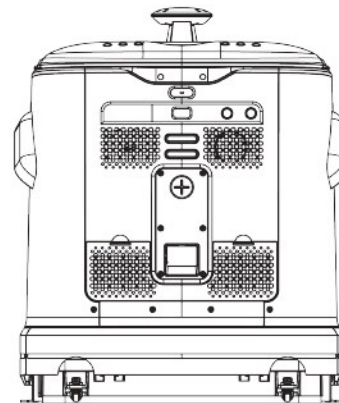

Press power key button

6.2 Charging Dock Deployment

- 1 It is advised to place the charging dock in a place with easy power supply and near the water discharging area. No object or obstacle is allowed within 1.5m at front of base station and within 0.5m at both sides of charging dock. Adjust the back support column to keep the support column of charging dock closely fitted to the wall.

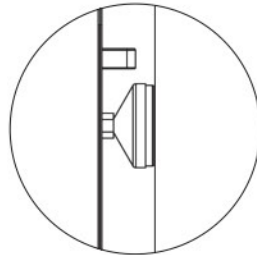
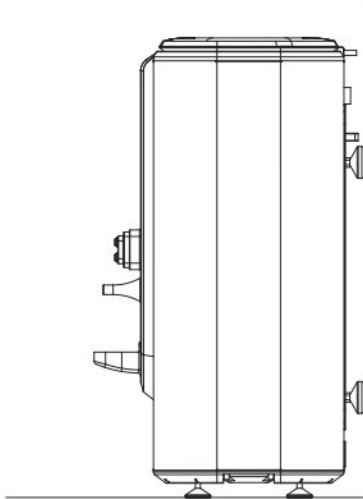

Rotate the button behind charging dock to keep charging dock closely fitted to wall and avoid shaking

- 2 Press emergency stop button to push the Product to charging dock position, rotate the four height adjustment buttons at the lower side of charging dock to adjust the height of charging dock.

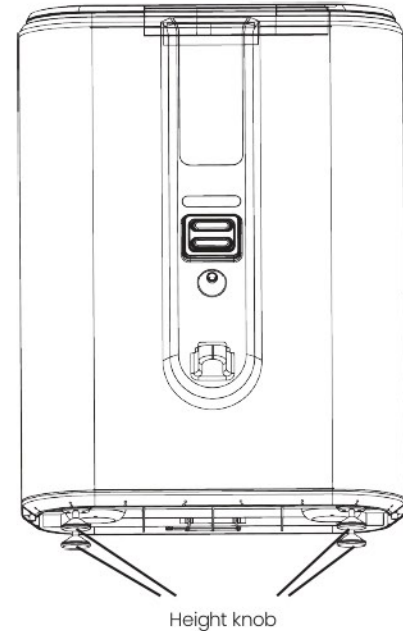

6. Preparatory work | Charging Dock Deployment

- 3 Align the charging port of charging dock with the rear charging port of robot, push the charging dock slightly until there's no shaking to complete the deployment.

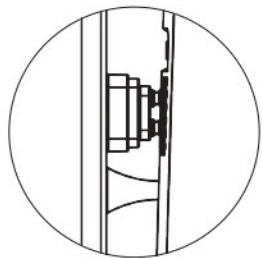
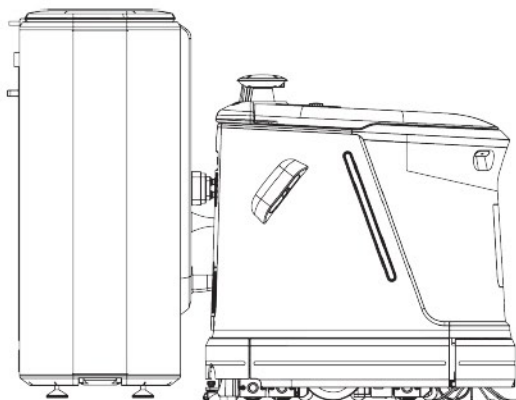

Full contact of metal sheet

- 4 Fill clean water into the left water tank through the rear water pipe of charging dock. The water level should not exceed the slot in tank.

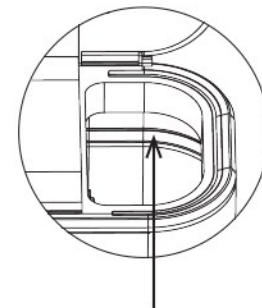
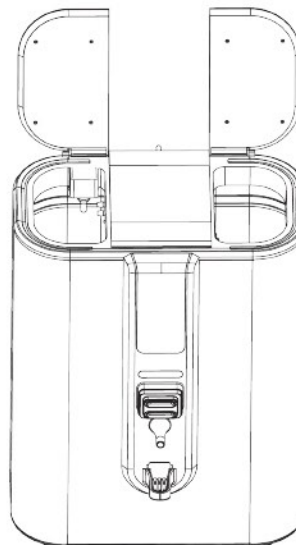

The slot on outer wall is the upper limit of water tank

6.3 First Charging of Robot

- 1 Connect the power cable of charging pile to the socket to ensure normal power supply of charging dock.

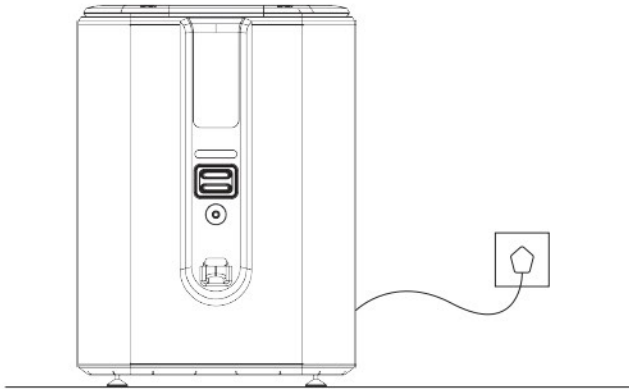

- 2 After power is supplied, the charging dock panel will reflect its real-time status through the indicator.

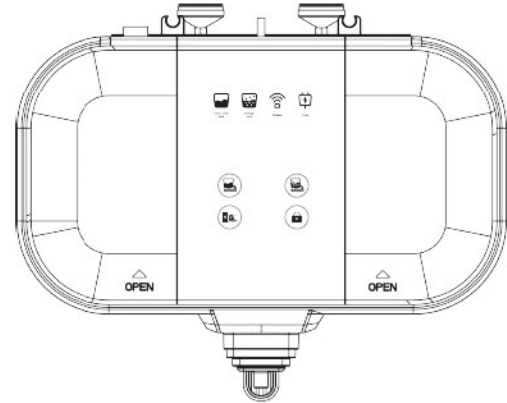

6. Preparatory work | First Charging of Robot

- 3 Press the Product's power switch to power it on, the blue indicator of power button will be on; meanwhile, all indicators above the pull rod will start flickering, which means the Product is under startup progress and has not completed startup yet.

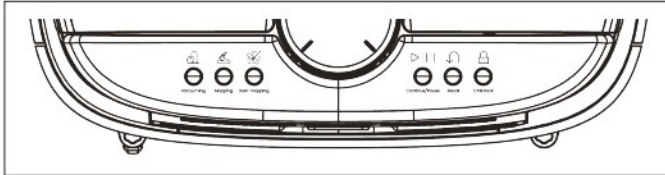

- 4 The Product's startup is completed when only child lock indicator on pull rod is on, while other indicators are off. Press emergency stop button of the Product and its expressions will change as shown in picture below.

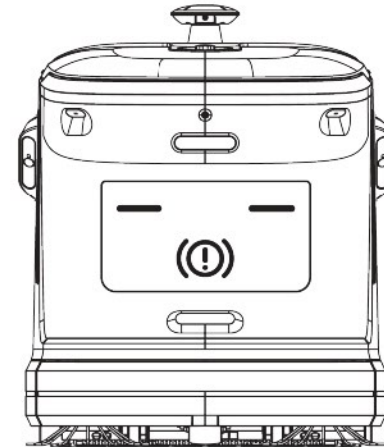

6. Preparatory work | First Charging of Robot

- 5 After procurement of the Product, the deployment person will provide the APP installation mode. After installation is done, the following APP will appear in your mobile phone.



- 6 Enter the APP and register, click the "Scan" button at the upper right corner, then scan the QR code behind the Product's top plate to bind the Product



6. Preparatory work | First Charging of Robot

- 7 After the QR code is identified, it will pop up the robot S/N, click it for binding. Complete binding if it is allowed and the information of new robot will appear in the robot list.

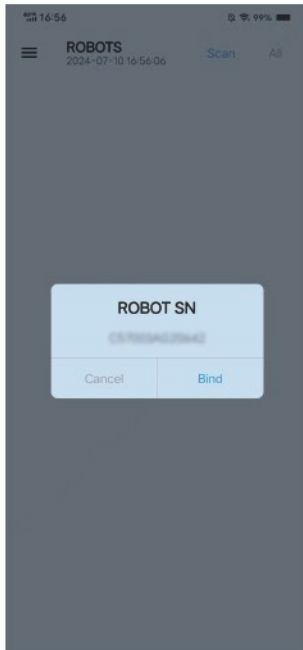

Click Bind

- 8 Click the robot name area to enter the "device information" page, click station to enter "modify device information" page.

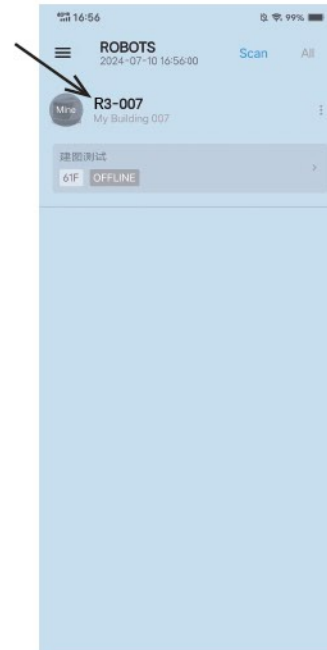

- 9 Click "Scan" in the column of station S/N.

ROBOT Reset

*Robot Name
R3-007

Alias Name
007

*Robot Floor Floors
61

Station SN Scan
Token between robot and station

Station Floor Floors
61

Next

61

Station SN Scan

Token between robot and station

Station Floor Floors
61

- 10 Scan the QR code at lateral side of base station, then the page will generate and fill the base station S/N automatically. Click "next" to confirm and take effects, and complete the binding between the Product and base station.

ROBOT Reset

*Robot Name
R3-007

Alias Name
007

*Robot Floor Floors
61

Station SN Scan
[QR Code]

Station Floor Floors
61

Next

ROBOT Reset

*Robot Name
Q3-007

Alias Name
007

*Robot Floor Floors
61

Station SN Scan
30

Station Floor Floors
61

Next

NOTICE
Send it right now
Cancel Yes

6. Preparatory work | First Charging of Robot

- 11 After startup of the Product, push the Product towards the charging dock until the Product's back has close contact with the metal of charging dock.

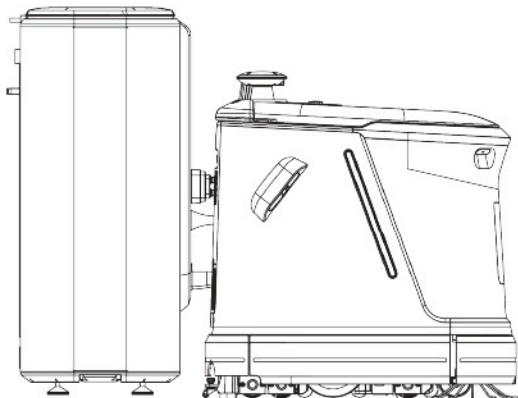

Full contact of metal sheet

- 12 Rotate the emergency stop button clockwise to bind it, and it will broadcast "emergency stop button bounced" and "original point locating"; then, the Product will show the lightning symbol at the mouth of expression, which indicates that the Product has entered charging status. When the battery level at the Product's mouth position is full, the battery charging is completed.

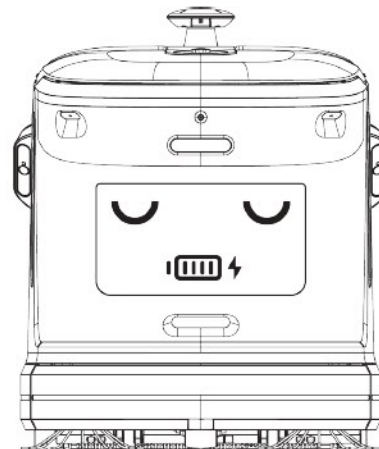

7.1 Side Brush Installation

- 1 The side brush can be installed without distinguishing the left and right side.

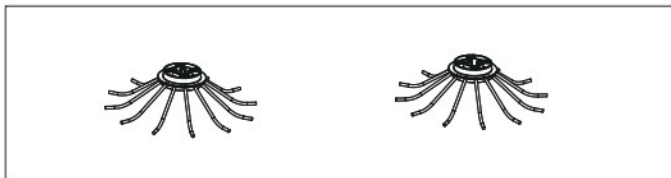

- 2 Insert the finger into the lateral side of the Product, to find the mounting bayonet at the raised position. The side brush and bayonet are magnet, so you just need to find the position and adjust it slightly to install them.

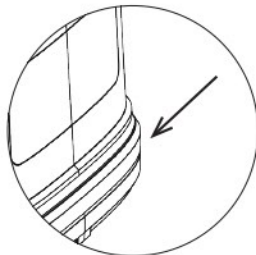

Insert your finger here

- 3 While installing the side brush, uplift the Product slightly and do not press the sensor.

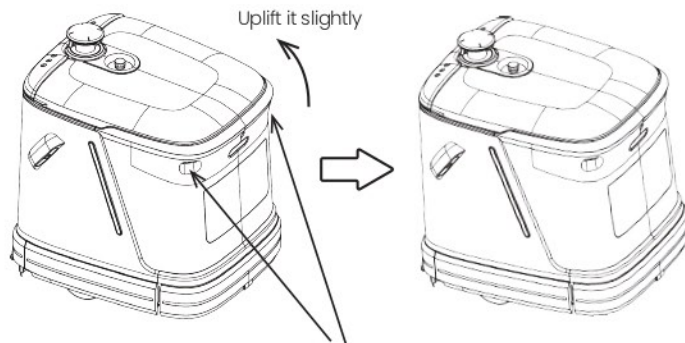

Do not press the sensor at both sides

7. Structural parts installation | Side Brush Installation

- 4 Put the side brush at the bayonet position, and rotate the side brush slightly till it is connected magnetically, to complete the installation.

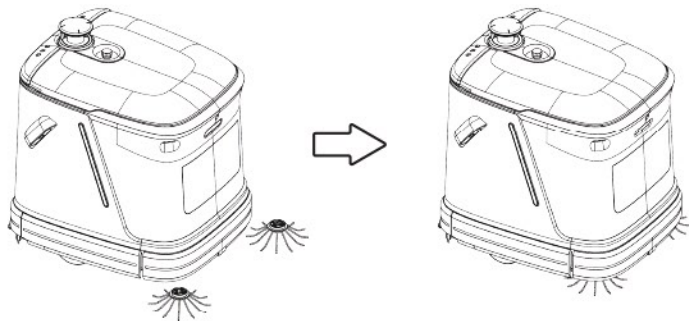

Mounting bayonet of side brush

Bottom view of robot

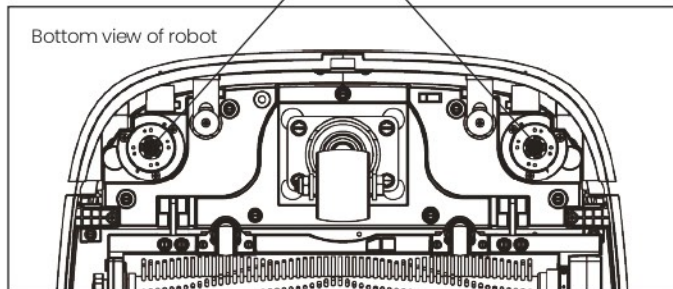

- 5 Grasp the hair of side brush and pull it downwards, then drag it outwards to complete dismantling of side brush.

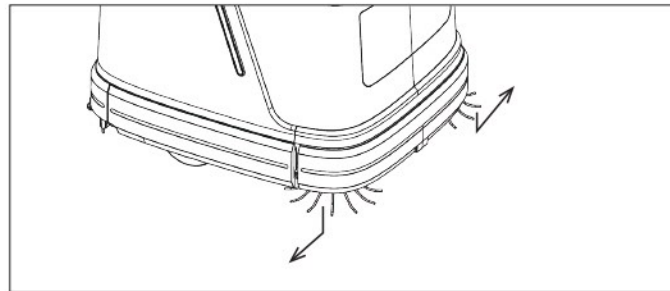

7.2 Rolling Mop Installation

There are two slots at the right rear side of the Product, in which, the one near wheel is rolling brush, while the one on the left side of rolling brush is rolling mop.

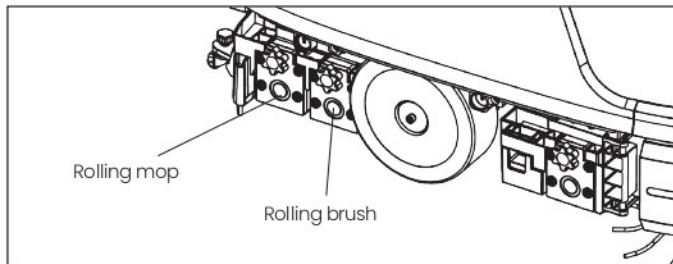

- 1 The arrow indicates the connection position between the rolling mop and the Product.

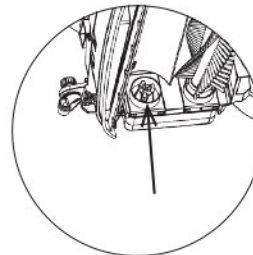
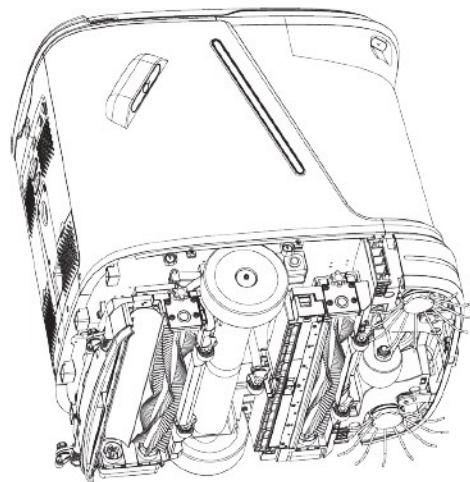

7. Structural parts installation | Rolling Mop Installation

- 2 Insert the rolling mop along with the rear hole till it reaches the lower side of the Product, use the left hand to find the corresponding connection port at the left side. If failing to insert the rolling mop, rotate it slightly with finger.

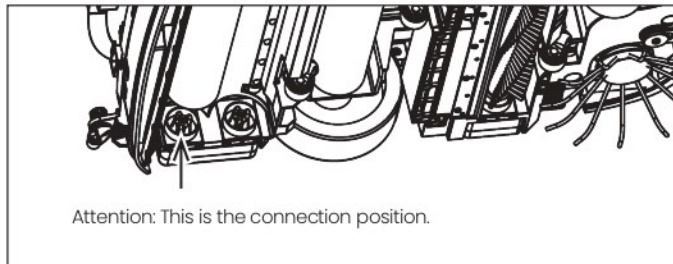
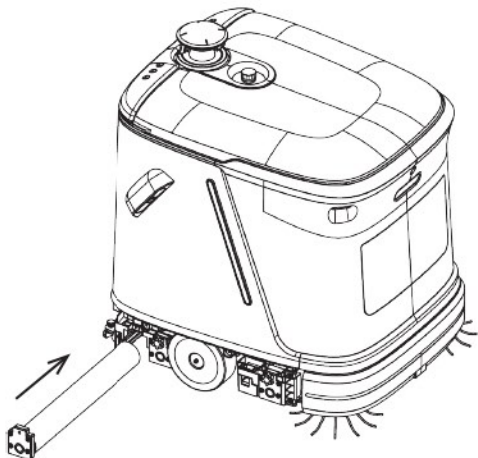

Attention: This is the connection position.

- 3 After the rolling mop is installed in the corresponding position, insert the screws to the upper screw port of rolling mop and fasten them clockwise to complete installation.

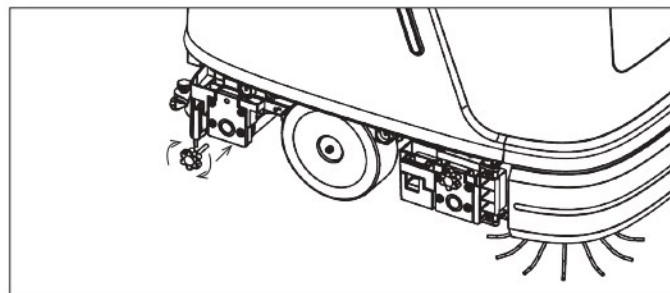
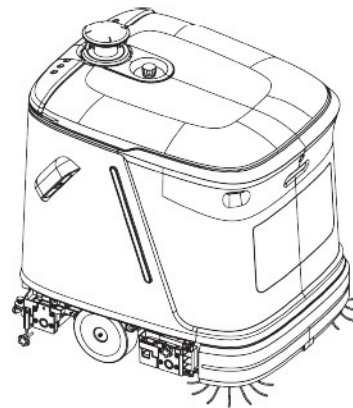

7.3 Rolling Brush Installation

There are two slots at the right rear side of the Product, in which, the one near wheel is rolling brush, while the one on the left side of rolling brush is rolling mop.



- 1 The arrow indicates the connection position between the rolling brush and the Product.

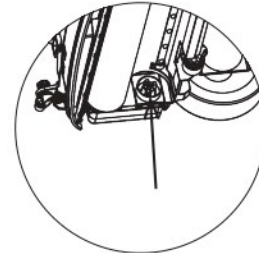
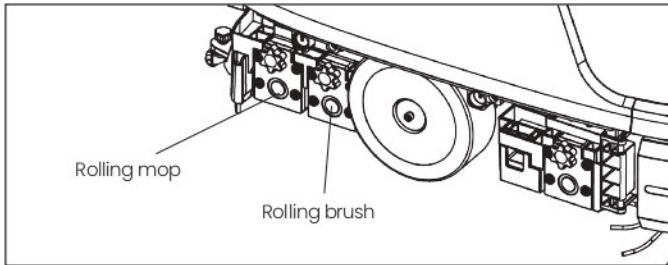
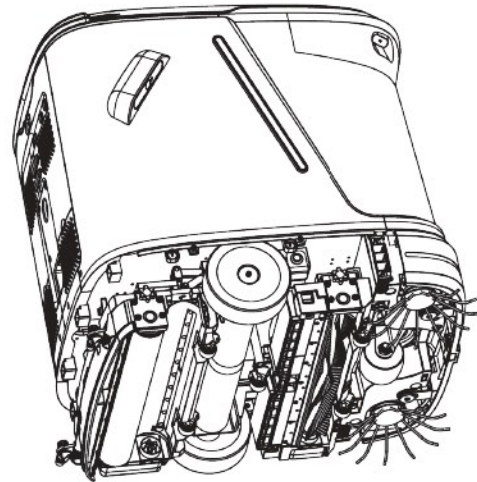

7. Structural parts installation | Rolling Brush Installation

- 2 Insert the rolling brush along with the hole till it reaches the lower side of the Product, and pay attention to the engagement at connection position. If failing to insert the rolling brush, pay attention to the engagement at connection position, and rotate it slightly with finger.

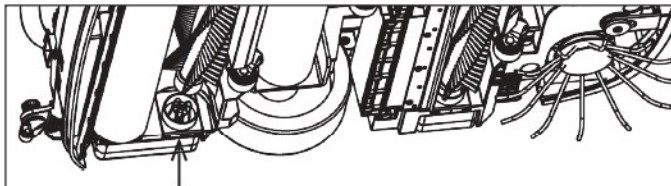
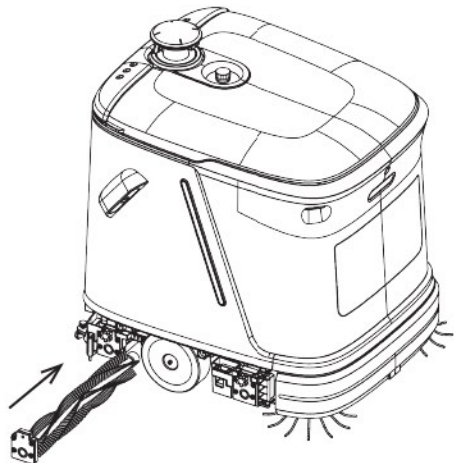

Attention: This is the connection position.

- 3 After the rolling brush is installed in the corresponding position, insert the screws to the upper screw port of rolling brush and fasten them clockwise, then recover the site plate to the original status to complete installation.

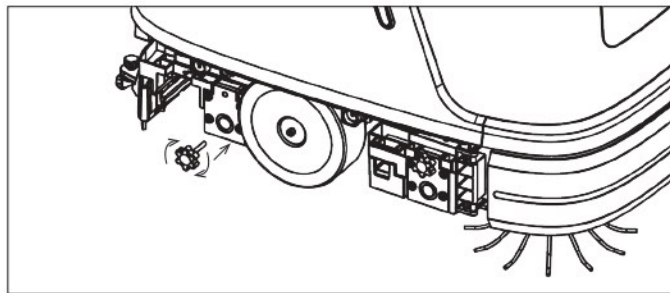

7.4 Wiper Plate Installation

1 Firstly, press the wiper plate component behind the Product.

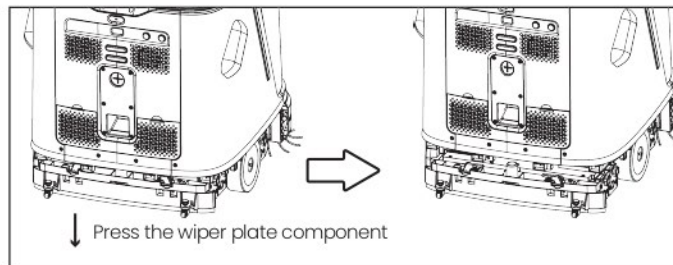
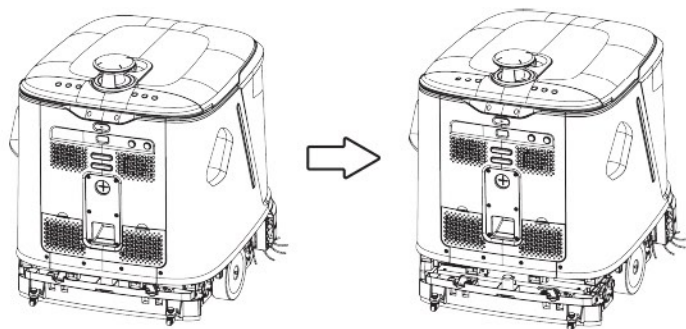

2 Second, open the lateral buckles behind the Product, as shown in the picture below.

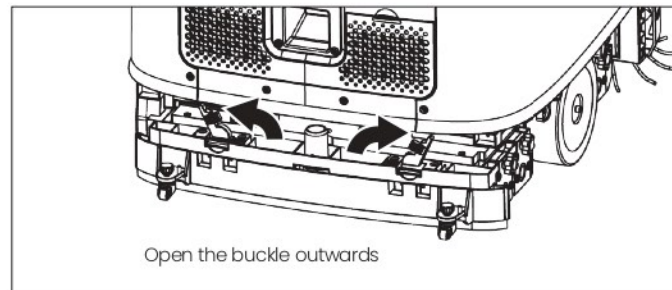

7. Structural parts installation | Wiper Plate Installation

- 3 Then, pull the paddles at both sides upwards as shown in picture below.

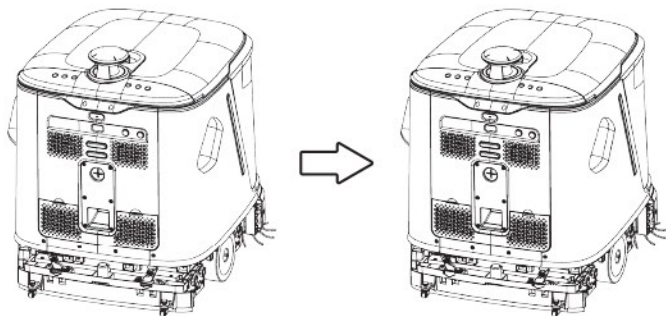

- 4 T-shaped bayonet is designed at both ends of wiper strip and robot tail respectively.

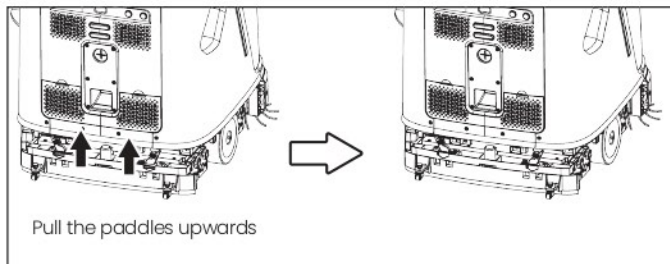
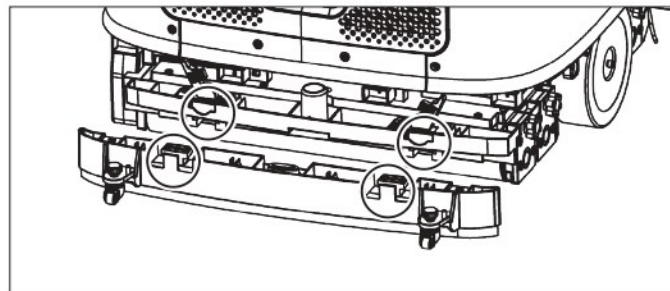

7. Structural parts installation | Wiper Plate Installation

- 5 Push the wiper strips horizontally into the corresponding holes and they are installed in place when there's no convex on the surface of wiper strip and the Product; then, press down the entire wiper strip.

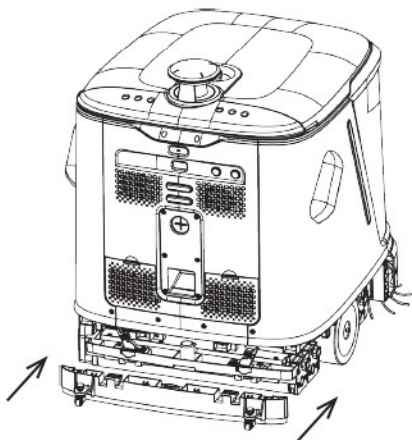

- 6 Then, press down the paddles, close the lateral buckles inwards to complete the installation of wiper strip.

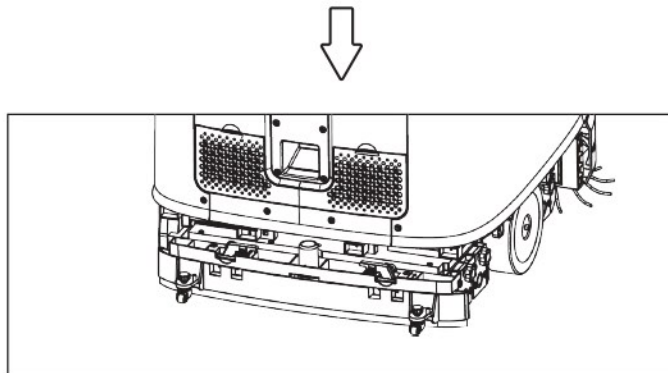
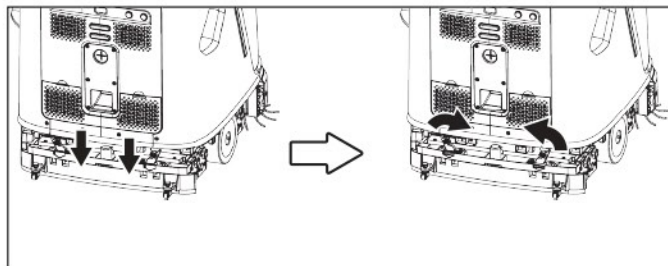

7.5 Side Plate Installation

1 There are two circular bayonet points at two side plates for connecting the Product. The side plate with magnet should face upwards.

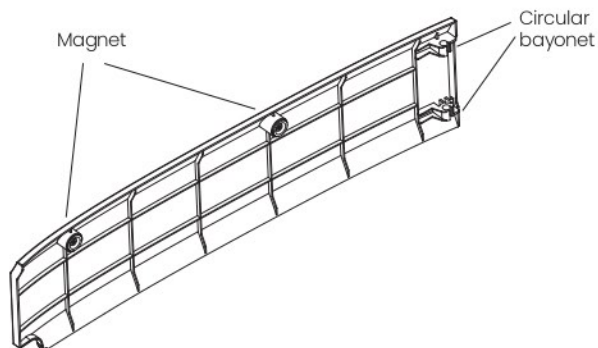

2 Move the side plate to the corresponding position, align it with the upper bayonet, fix the side plate in the corresponding position; both the upper and lower side should be blocked.

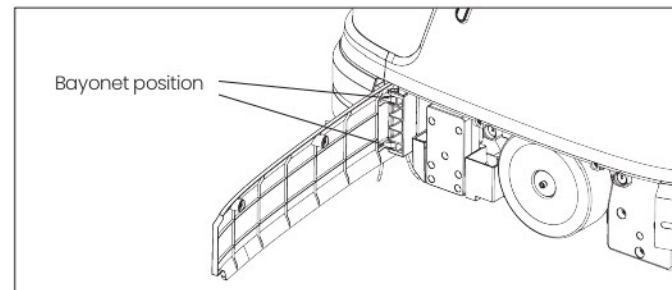
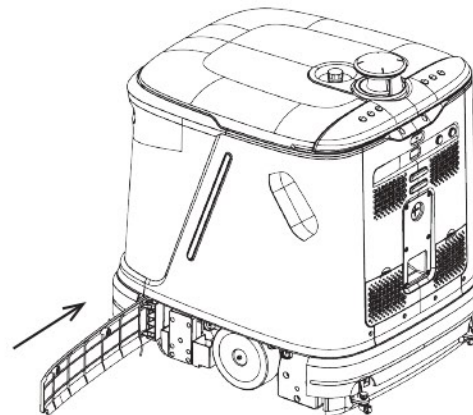

- 3 After insertion, retract the side plate and have magnetic connection to complete the installation.

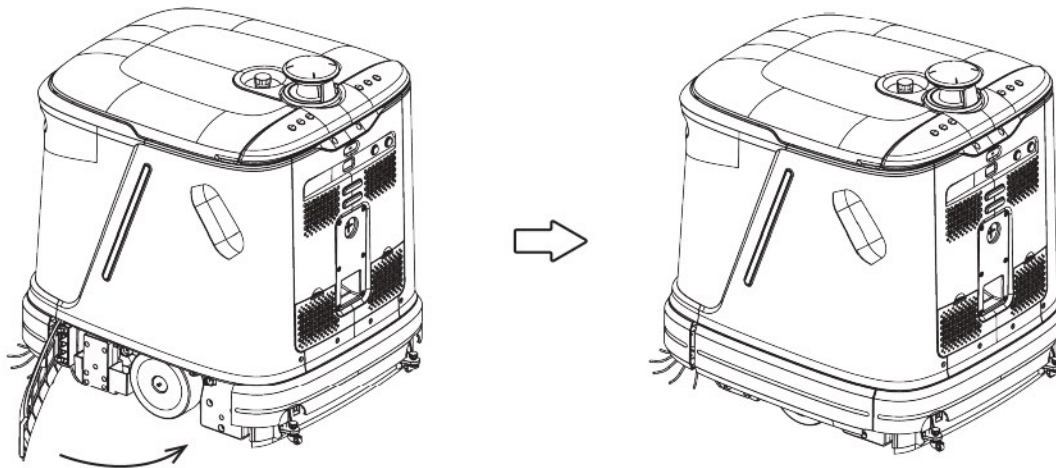

7. Structural parts installation | Installation of Rear Cover Plate

7.6 Installation of Rear Cover Plate

- 1 The rear plate has four square magnets which respectively correspond to the four square slots at the end of the Product. Such magnets should be aligned with the Product's slots.

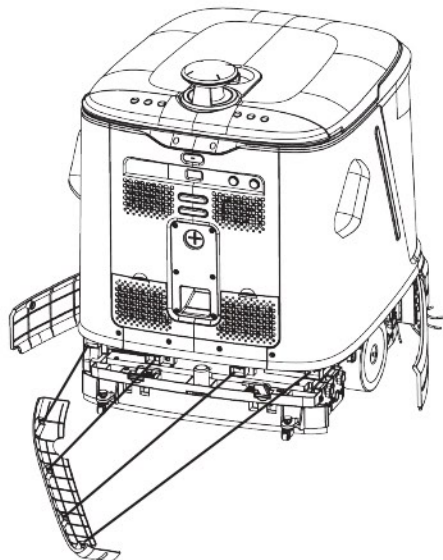

- 2 When the bayonet at one side has slight convex after magnet connection, flap it gently to complete installation.

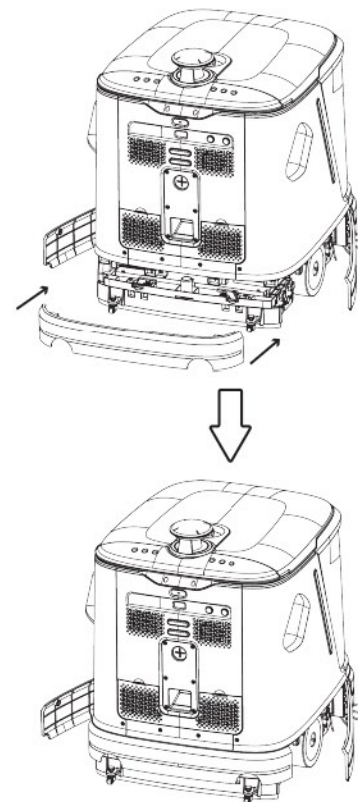

8.1 Dismantling of Robot Side Plate

- 1 Insert the finger behind the Product, uplift the side plate gently to open the left cover plate to the maximum position.

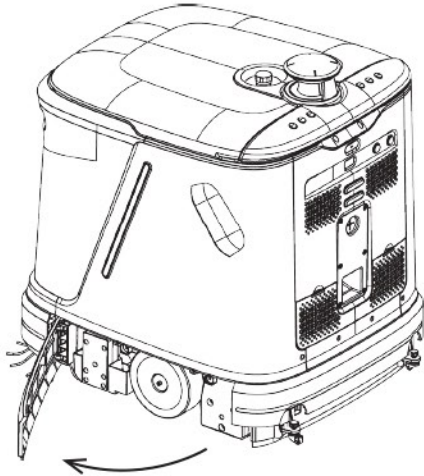

- 2 Draw out the open the side plate. The side plate at the other side can be dismantled in the same way.

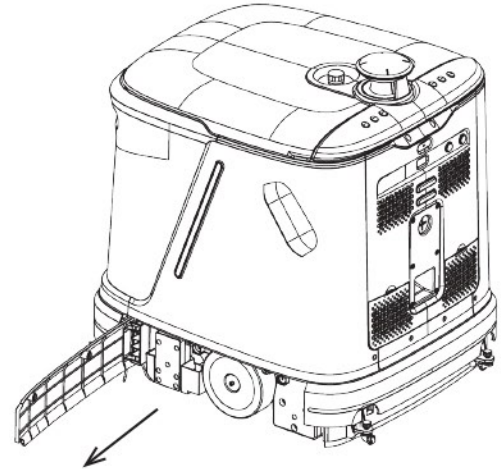

8. Structural Parts Disassembly | Dismantling of Rear Cover Plate

8.2 Dismantling of Rear Cover Plate

1 After opening the cover plate at both sides, hold the Product with the thumbs at both sides of hands which are fixed at the rear plate.

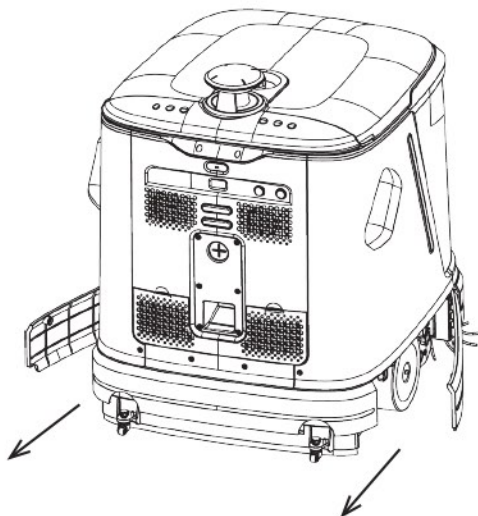

2 Exert force outwards to dismantle the rear plate successfully.

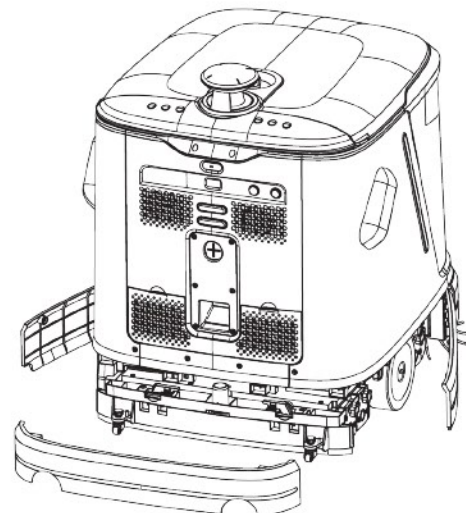

Robot	
Product Name	Cleaning Robot
Model	R3 -D、 R3 -G
Battery	45Ah Ternary lithium / 37.5Ah Lithium iron phosphate
Product weight	53.8KG
Rated input	DC29.5V \approx 20A
Noise	<65dB
Duration	5h - Scrubbing, 5h - Vacuuming, 18h - Sweeping, 10h - Dust Moppin
Charging period	2h

Charging Dock	
Product Name	Multi- Functional Charging Dock
Model	R3 -C
Voltage	AC100-240V
Product weight	25KG
Rated input	AC100-240V 50/60Hz 3A
Rated output	DC29.5V \approx 20A
Rated power	600W
Maximum charging current	20A

Product model: R13-D is Single Suction Port version, R3 -G is Rolling Brush Version.

10. Common Problems

Problem Type	Solutions
Whether it has power consumption during constant charging at charging dock	The Product has ultra-low power consumption during charging at the charging dock, which can help maintain the optimal performance of battery.
There's abnormal sound during cleaning	The rolling brush, rolling mop, side brush or main wheel can be twined with foreign matters, please power off the Product and clean it.
Charging is slow	When the Product is used at high or low temperature, the charging speed will be lowered automatically in order to prolong the service life of battery.
Water suction failure under cleaning mode	The water suction pipe is blocked. Firstly, remove the wipe strip, use the attached cleaning brush to insert the pipe, which is at the bottom wiper of robot, from bottom to top, shake it up and down repeatedly until the pipe is unblocked.
Alarm of dust/water suction fan blockage	The Product's pipe is blocked. Firstly, open the cover, uplift the dust bag/sewage tank in the Product, use the attached to insert the pipe from the top, shake it up and down repeatedly until it is unblocked.
Alarm of dust box blockage	The Product's dust bag is full. Open the cover, uplift the dust bag in the Product, hold the dust bag with hand and open it slowly, pour the waste in the dust bag and then cover it to the dust box.

11. Service Life of Relevant Components

Name	Replacement Period (taking marble floor as an example)
Battery	2-3 years, if being charged/discharged for 2 times each day
Sewage tank filter	1-3 days (it can be washed circularly)
Front/rear wiper strip	Replaced once a month
Rolling brush	Replaced in every 1-2 months
Rolling mop	Replaced in every 1-2 months
Clean water filter	Replaced in every 1-2 months
Disposable paper dust bag	1-3 days (replaced when it is full)
Dust tank filter	1 week
Sewage filter	1 week
Side brush	1-2 months

Note: The use period varies along with the floor.

SLIP

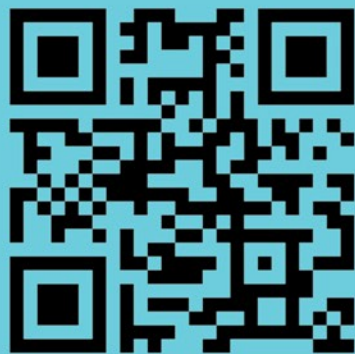

 **ROBOT
INDUSTRIES**
PIONEER OF ROBOTIC APPLICATIONS